

CUPOLEX® CUPOLEX H 60cm (23.62")

CUPOLEX® Plastic Dome Shaped Concrete Forms are stay-in-place forms to create unreinforced or reinforced concrete slabs on grade. Concrete is poured over the modular dome forms to create floating or structural grade supported slabs, partially supported or fully supported slabs on beam, piles or deep foundations. CUPOLEX® slabs use less concrete and reinforcing than a standard slabs with equivalent load bearing capacity. The unique concrete geometry Cupolex creates, forms an under slab void that can be passively or mechanically vented to remove moisture and soil gases, protecting buildings against the ingress of harmful soil gasses.

CUPOLEX® Patented Forms have a unique connecting feature. Only, CUPOLEX® forms additional built-in plastic at all pressure point locations and a central reinforced cone support of height equal to the element positioned in correspondence of the central region, guarantees the absorption of vibrations which occurs during the finishing of the CUPOLEX® aerated concrete floor slab.

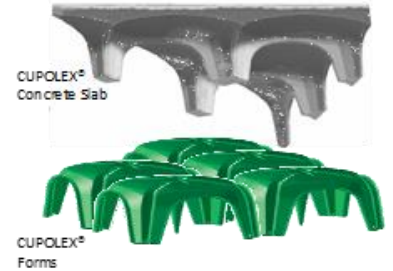

Applications

- Radon & Soil Gas (VI) Mitigation
- Alternative to Structural Fill
- Structural Slab Foundations
- Concrete Slab on Grade
- Concrete Structural Supported Slabs
- Concrete Pavements and Roads
- Pavements for Creating Soil Cells
- Replacing Gravel Drainage Layers
- Replacing Vapor Barriers & Liners
- Concrete Water Detention Tanks
- Water Infiltration Tanks
- Solution for Structural Weight Limits
- Refrigeration & Freezer Floors
- Building Green With LEED
- Challenging & Expansive Soils
- Concrete Crawl Space Floors
- Technical/Electrical Sub Floors
- Acoustical Floors



Advantages

- Arrives on site packaged and ready to be installed
- Quick and simple to install with basic hand tools
- Can be easily adapted to site variations
- Minimizes concrete wastage
- Made out of 100% non-toxic recyclable material which contributes to LEED certified building
- One pallet of CUPOLEX replaces 7.5 trucks of gravel or fill
- Minimizes construction traffic damage
- Manufactured to ISO 9001:2000 high quality standards
- A full range of accessories and field support ensures secure construction

Installation

CUPOLEX® provides Excellent Flexibility in Working with new construction or remodeled building layouts. The main characteristics of the forming system are speed and simplicity; the following points should be adhered to:

- On average two laborers set 110 m²/hr (1200 sf/hr)
- Layout complies with a grid system
- Can be installed on any resting surface - soil, gravel, mud slab, etc.
- Each CUPOLEX® Form has an installation arrow
- Forms are installed by starting from left to right and top to bottom
- Ensure that the feet connection pins are correctly inserted into their connection holes
- Pouring and finishing of the concrete slab in the conventional manner

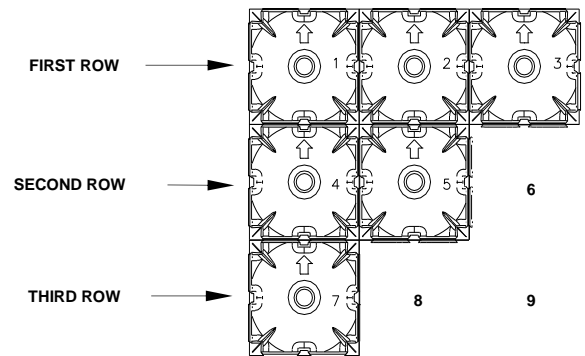

Product Data

Made from 100% recycled Polypropylene (PP) plastic, the CUPOLEX® forms provide the maximum performance and guarantees superior characteristics of stability and resistance in its structure to allow operations that are completed directly above the plastic CUPOLEX® elements before and during the placement of the concrete. CUPOLEX® Forms are molded in a variety of depths to deal with different levels of Vapor emission and for different depths of fill requirements.

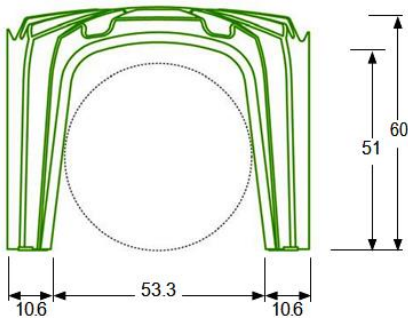
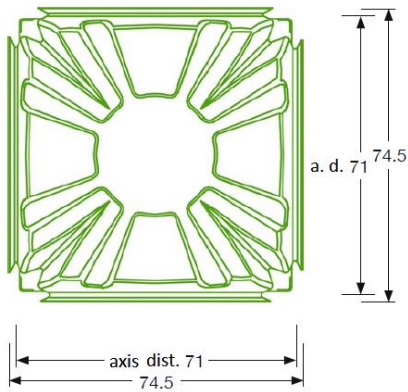

Concrete Consumption: 0.07m³/m² (0.0085cy/sf)

Ancillary Products

BETON STOP®: Element for closing the side openings of the CUPOLEX® forms.



Storage & Handling

- All products are delivered on heat treated wood pallets with polythene wrapping
- Handle CUPOLEX® with safety gloves and safety glasses
- Avoid impact
- Avoid tipping CUPOLEX® pallets
- See specific instructions for installing product in temperatures below 0°C or above 35°C.
- CUPOLEX® waste can be completely recycled.

Packaging

CUPOLEX® is packaged on heat treated wood pallets wrapped with cellophane and certified for international shipping.

Pallet Dimension: 1.2m x 1.2m x h 2.0m (4' X 4' X h 6.5')

No. Of Units per Pallet: 50

Area per Pallet: 26.60m² (286.32sf)

Weight per Unit: 3.66kg (8.07Lbs)

Total Weight per Pallet: 183kg (403Lbs)

Material

Made from 100% recycled Polypropylene (PP) plastic. The forms provide the maximum performance and guarantees superior characteristics of stability and resistance in its structure to allow operations that are completed directly above the plastic CUPOLEX® elements before and during the placement of the concrete.

Issued 01/16

Consistent with manufacturer Pontarolo Engineering's policy of continued research and development, we reserve the right to modify or update the information contained in this or any other material published by Pontarolo Engineering®. The onus remains on the user of CUPOLEX® to obtain the most recent information available. Because Pontarolo Engineering® has no control over the installation, workmanship, accessory materials or conditions of application, no responsibility or expressed or implied warranty, either as to merchantability or fitness for a particular purpose, is made as to the performance or results of an installation using CUPOLEX® Forms, except that the physical characteristics of CUPOLEX® Forms shall meet or exceed the specifications published by Pontarolo Engineering®.

Cupolex®, Beton Stop®, Pontex®, Cupolex Windi®, Cupolex Rialto®, Cupolex Building Systems®, and any other marks, drawing or symbols identifying products and/or services of Cupolex Building Systems are trademarks of Pontarolo Engineering Inc.

